



## LED Light Kit Installation Instructions

Covers Parts #8025, 8026, 8027, 8028, 8029, 8030

### #8025 Kit Contents:

- LED light bar
- 2.5x6mm cap screws (2)
- Zip tie (1)

### #8026 Kit Contents:

- LED rock light harness assembly
- Zip ties (3)

### #8027 Kit Contents:

- LED headlight/tail light harness assembly
- Zip ties (5)

### #8028 Kit Contents:

- LED lighting module
- 3-in-1 wire harness
- 2.5x15mm cap screws (2)

### #8029 Kit Contents:

- LED light bar
- LED lighting module
- 3-in-1 wire harness
- 2.5x15mm cap screws (2)
- 2.5x6mm cap screws (2)
- Zip tie (1)

### #8030 Kit Contents:

- LED light bar
- LED rock light harness assembly
- LED headlight/tail light harness assembly
- LED lighting module
- 3-in-1 wire harness
- 2.5x15mm cap screws (2)
- 2.5x6mm cap screws (2)
- Zip ties (9)

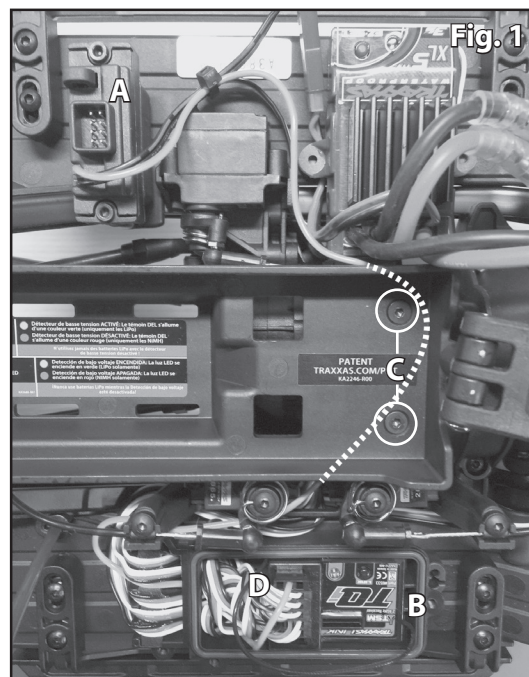

### LED Lighting Module Installation (Fig. 1):

1. Install the LED lighting module (A) on the left chassis floor pan. Secure with the 2.5x15mm cap screws (2).
  2. Remove the screws from the receiver box cover and wire clamp; remove the cover and clamp (B).
  3. Remove the two 3x10mm countersunk cap screws from the battery tray (C).
  4. Lift up the battery tray and route the red wire (male connector) from the LED lighting module to the right side of the chassis, between the two T-Lock servos, and through the hole in the the receiver box. Plug the connector into channel 1 of the receiver (D).
- Note:** The connector can be plugged into any non-telemetry channel on the TQi receiver.
5. Apply an additional bead of silicone grease (Traxxas part #1647, sold separately) to the wire clamp. The grease will improve sealing. Reinstall the clamp and screws.
  6. Make sure the o-ring is properly seated into the groove in the receiver box so that the cover will not pinch it or damage it in any way.
  7. Install the cover and screws. Inspect the cover to make sure the o-ring seal is not visible.
  8. Reinstall the screws in the battery tray.
  9. Connect the black wire (red female connector) from the LED lighting module to the red wire (male connector) exiting the XL-5 HV electronic speed control.

### Body disassembly (Fig. 4):

1. Remove the headlights (E), tail lights (F), fender flares (G), inner fenders (H), and rock light covers (I). You do not need to remove the spare tire carrier assembly from the body; only remove the two 4x5mm screw pins (J) that attach the rear inner fender support to the tire carrier assembly.

### LED Light Installation (Fig. 5):

1. Install the LED light kits; refer to the wiring diagram. The headlights, tail lights, and rock lights install as assemblies using the same hardware as the original assemblies. When installing the rock lights, note where the light string begins and ends in the wiring diagram. Do not overtighten the screws that fasten the rock lights to the inner fenders. Hand tighten these screws.
2. When installing the LED light bar, use a body reamer or a cutting bit on a rotary tool (such as Dremel®) to cut a small hole in the front left corner of the roof of the vehicle body (Fig. 2). DO NOT use a drill bit as it will catch in the body and tear it. The hole or slot needs to be large enough to pass the connector for the light bar through the body. **Note:** It is important to cut the hole in the correct location or the light bar will not mount correctly. Secure the light bar to the roof rack using the 2.5x6mm cap screws.
3. Reinstall the inner fenders and fender flares (hand tighten the screws in the fender flares to avoid distorting or damaging the parts).
4. Use zip ties to secure the wiring to the body in the locations provided (Fig. 3).

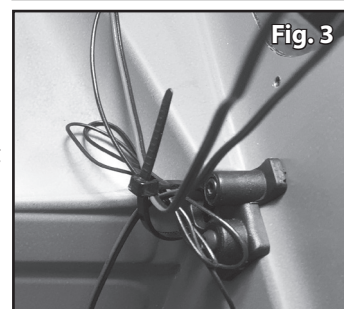
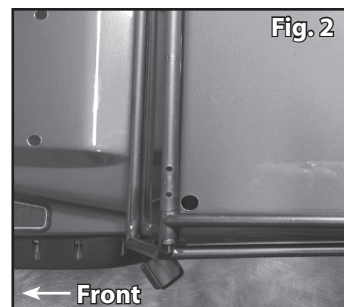

Assembly Diagram

Fig. 4

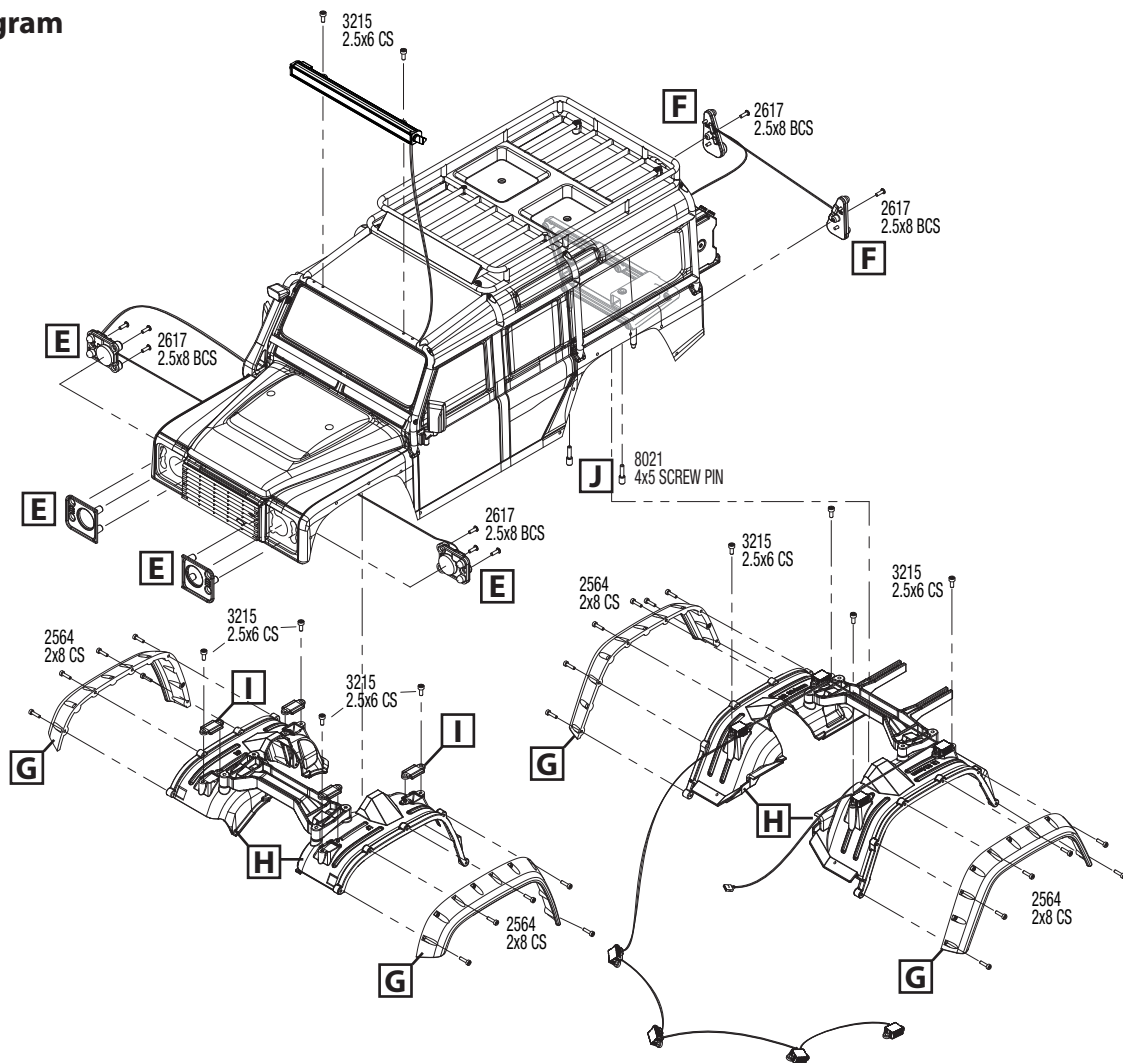

Wiring Diagram

Fig. 5

