

HUBSAN X4

2.4GHZ RC SERIES 4 CHANNEL



ITEM NO.: H107P

TABLE OF CONTENTS

1 FOREWORD	02
2 SAFETY INSTRUCTIONS	02
3 PRE-FLIGHT CHECKLIST	05
4 AIRCRAFT BATTERY & CHARGING	06
5 THE TRANSMITTER	
5.1 GETTING TO KNOW YOUR TRANSMITTER	07
5.2 TRANSMITTER BATTERY INSTALLATION	09
6 FLIGHT	
6.1 POWER-UP SAFETY PROTOCOL	10
6.2 HEADLESS MODE	11
6.3 BASIC FLIGHT OPERATION	11
6.4 ARMING/DISARMING THE MOTORS	13
7 ADVANCED FLIGHT SETTINGS	
7.1 NORMAL AND EXPERT MODE	14
7.2 ACRO MODE	14
8 INSTALLING AND REMOVING PROPELLERS	16
AIRCRAFT EXPLODED VIEW	17
H107P FREQUENTLY ASKED QUESTIONS	19
H107P PARTS & ACCESSORIES	22

1 FOREWORD

Thank you for purchasing a HUBSAN product. The H107P is an easy to fly aircraft capable of a variety of flight functions. It is equipped with a full-function remote control. Please read and follow the manual carefully for proper operation and use. Be sure to keep the manual as important reference for future routine maintenance.

2 SAFETY INSTRUCTIONS

2.1 Precaution

This remote control quadcopter is not a toy. Please read this manual carefully before operating this product. Improper use of the product may result in serious injury. Please be aware of the environment around you and take appropriate measures to ensure the safety of yourself and others. We recommend that you make your first flight under the guidance of an experienced pilot.

2.2 Warning

This aircraft is made of components that rotate at high speeds, which constitutes a certain degree of danger. The user must be responsible for any damage and loss caused by improper use.

Do not fly in crowded places such as people, poles, motor vehicles, roads, or near airports. Remember that you are responsible for the safety of yourself and others.

Please operate only while alert and sober. Do not operate this product while fatigued or drunk. This can be dangerous.

2.3 Battery And Charging

Your quadcopter is equipped with a lithium polymer battery (LiPo).

If you plan not to use the product for a week or more, leave the battery at 50% to preserve the battery's overall lifespan. To do so, charge the battery for half the time it takes for the battery to fully charge.



WARNING

Using the type of wrong battery may cause explosion.

Please dispose of used batteries in accordance with relevant laws and regulations.



SAFETY ADVISORY (LITHIUM-POLYMER/LI-PO BATTERIES)

LiPo batteries are different from conventional batteries in that their chemical contents are encased in a relatively lightweight foil packaging. This has the advantage of significantly reducing their weight but it does make them more susceptible to damage if roughly or inappropriately handled. As with all batteries, there is a risk of fire or explosion if safety practices are ignored.

Do not disassemble or reassemble the battery.

Do not short-circuit the battery.

Do not use or charge near sources of heat.

Do not put the battery in contact with water or any kind of liquid.

Do not puncture or subject the battery to force of any kind.

Do not throw or manhandle the battery.

Never charge a battery that has been damaged, become deformed or swelled.

Do not solder on or near the battery.

Do not overcharge or over discharge the battery.

Do not reverse charge or reverse the battery polarities.

Do not connect the battery to a car charger/cigarette lighter or any other kind of unconventional power source.



SAFETY ADVISORY (LITHIUM-POLYMER/LI-PO BATTERIES)

This battery is prohibited for non-designated devices.

Do not touch any kind of liquid waste or byproduct from batteries. If skin or clothes come in contact with these substances, please flush with water!

Do not mix other types of batteries with lithium batteries.

Do not exceed the specified charging time.

Do not place the battery in a microwave or in areas of high pressure.

Do not expose the battery to the sun.

Do not use in environments with high static electricity (64V and above).

Do not use or charge in temperatures below 0 °C and above 45 °C.

If a newly purchased battery is used, leaking, possesses a bad smell or any other abnormality, return immediately to the vendor.

Keep away from the reach of children.

Use a dedicated battery charger and follow all charging requirements.

Minors who use the battery and its dedicated unit must be supervised by an adult at all times.

2.4 Protection Against Water & Dampness

There are many small electrical components in the model. It is important to store/fly the model in a suitable environment and to avoid placing it around other appliances. Exposing the model to water or a humid environment may cause failure and damage.

2.5 Correct Operation

For safety reasons, use only Hubsan parts for replacement and repair.

2.6 Pay attention to the rotating blades

During operation, high speed rotating propeller blades can cause serious bodily injury or damage to the aircraft. Do not approach the aircraft in flight and do not let it fly out of your line of sight. If this happens, disarm the motors or power off the aircraft immediately.

2.7 Avoid Flying Alone

Beginners should avoid flying alone before learning and mastering flying skills. It is recommended to operate under the guidance of an experienced pilot.

3 PRE-FLIGHT CHECKLIST

- Before operating, fully charge the remote control and the aircraft.
- Before turning on the switch, check that throttle is in its lowest position.
- Check the aircraft chassis and propellers carefully. Broken or failed parts may cause danger.
- Turn power on the remote control first, then the aircraft. After use, first power off the aircraft and then the remote control. An incorrect operation sequence may result in losing control of the aircraft.

4 AIRCRAFT BATTERY & CHARGING

4.1 The 3.7v 520mAh LiPo

Be sure to use the provided Hubsan dedicated charger for charging. Fully charge the battery before flight. Connect the charger's USB adapter to a PC terminal and then the battery to the charger. Charging time is approximately 80 minutes; recommended flight time is 6 minutes.

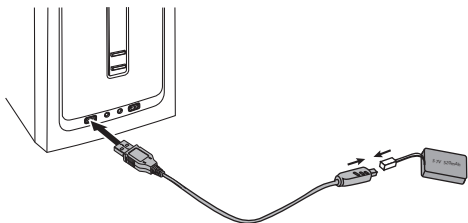

When charging is complete, disconnect the charger and battery from power immediately.

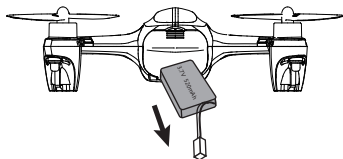

4.2 Safety Precautions

Lithium batteries do not need to be recharged when in stored short-term. When it is necessary to store the lithium battery unused for more than 3-6 months, it is necessary to charge the lithium battery to recover lost voltage.

If your battery is overly discharged, you may not be able to recharge it.



Lithium battery disposal and recycling



Lithium batteries cannot be disposed with household waste. Please contact your environmental protection department or waste collection agency or dispose of the battery at nearest lithium battery recycling center in accordance with local regulations.

5 THE TRANSMITTER

5.1 Getting To Know Your Transmitter

Main Interface

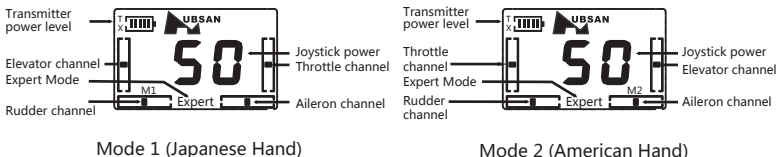

Transmitter

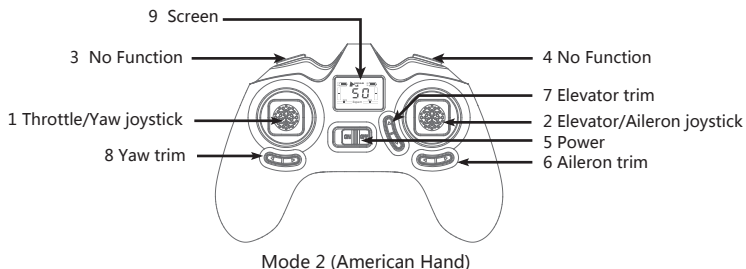
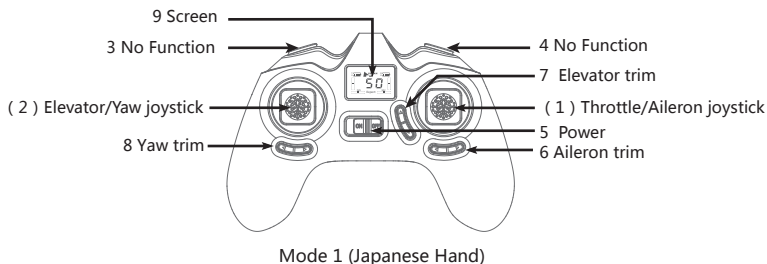

Transmitter Key Functions

S/N	KEY/SWITCH	FUNCTION
1	Throttle/Rudder stick	Push the stick forward or backward and the quadcopter will ascend or descend (respectively). Push the stick left or right and the quadcopter will rotate counterclockwise or clockwise (respectively).
2	Elevator/Aileron stick	Push the stick forward or backward and the quadcopter will fly forwards or backwards (respectively). Push the stick left or right and the quadcopter will fly left or right (respectively).
(1)	Throttle/Aileron stick	Push the stick forward or backward and the quadcopter will ascend or descend (respectively). Push the stick left or right and the quadcopter will fly left or right (respectively).
(2)	Elevator/Rudder stick	Push the stick forward or backward and the quadcopter will fly forwards or backwards (respectively). Push the stick left or right and the quadcopter will rotate counterclockwise or clockwise (respectively).
3	No Function	\
4	No Function	\
5	Power	Push left/ON to turn on the transmitter. Push right/OFF to turn off.
6	Aileron trim	Use the Aileron trim to adjust for left (trim the channel right) horizontal drift and right horizontal drift (trim the channel left).
7	Elevator trim	Use the Elevator trim to adjust for forward and backward drift.
8	Rudder trim	Use the Rudder trim to adjust for counterclockwise and clockwise rotation/yaw drift.
9	Screen	Displays the aircraft's current status.



Environmental Impact

Old appliances cannot be processed together with ordinary garbage. Please dispose of them separately. Usage of public waste collection points is typically free and owners of old appliances have the obligation and responsibility to send used electrical appliances to these waste collection point for disposal. Through our personal efforts, we can repeatedly use valuable raw materials and mitigate the uncontrolled release of harmful substances.

Do not mix new and old batteries.



Do not cross-use different types of batteries at the same time.

Do not charge with non-rechargeable batteries.

5.2 Transmitter Battery Installation

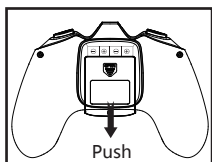

Open the battery compartment.

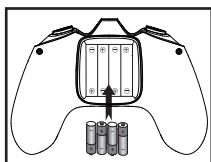

Install 4 AAA batteries (be sure to match polarities correctly).

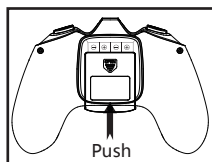

Slide the battery door back onto the compartment.

6 FLIGHT

6.1 Power-Up Safety Protocol

Your aircraft has a power-up safety protocol. When both your remote control and the aircraft are powered on, the aircraft motors will not start up unless an arming signal is detected.

6.1.1 Power on the remote and watch the aircraft parameters appear on the remote control screen. Please do not touch any joysticks or buttons before the transmitter and the aircraft finish pairing, otherwise the aircraft may roll over.

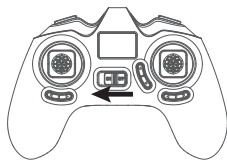

6.1.2 Push the battery into the battery compartment as shown in the figure, connect the power adapters, coil the power cord into the aircraft and close the battery compartment.

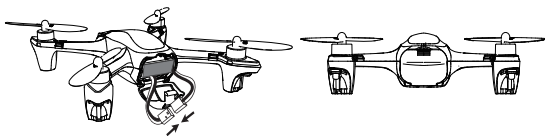

6.1.3 Aircraft Status Indicator

The transmitter will beep and the aircraft's LEDs stop blinking to indicate that two are properly bound.

Low battery alarm: When the aircraft battery is low, the aircraft's two red LEDs flash simultaneously. The aircraft automatically descends from a height of 5 meters or less.

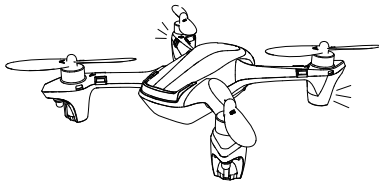

6.2 Headless Mode

To access Headless Mode, *first* make sure that you "set" a forward direction. Say, you'd like to consider due North as your "forward" direction. Have the drone's head facing North- then and only then, initiate Headless mode. During Headless Mode, the aircraft's blue LEDs will be flashing together simultaneously. The "Headless" symbol will also come on-screen.

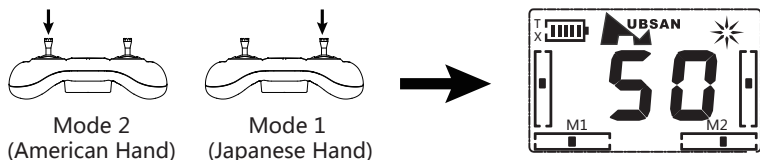

Press down onto the throttle joystick (you should feel and hear a click) to enter or exit Headless Mode.

Short press the throttle joystick to enter Headless Mode and the "✱" symbol will appear on the remote control screen.







Short press the throttle joystick to exit Headless Mode and the "✱" symbol will disappear from the remote control screen.

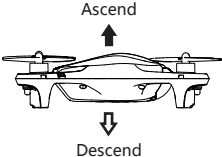

6.3 Basic Flight Operation

The remote control is by default set to Mode 2 in factory. This manual will introduce flight operations in Mode 2.

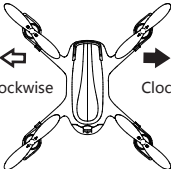
-Transmitter joysticks are self-centering and spring loaded: the joysticks will automatically center themselves

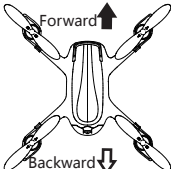
-Joystick sensitivity: dependent how much and how forcefully each joystick is pulled or pushed away from center point

REMOTE CONTROL	AIRCRAFT
<div style="display: flex; justify-content: space-around;"> <div style="text-align: center;">  <p>Mode 2 (American Hand)</p> </div> <div style="text-align: center;">  <p>Mode 1 (Japanese Hand)</p> </div> </div>	<div style="text-align: center;">  <p>Ascend</p> <p>Descend</p> </div>
<p>The throttle is used to control the ascent and descent of the aircraft. Push the throttle up and the aircraft ascends. Pull the throttle back and the aircraft descends. When the joystick is centered (unmoving), the aircraft will hold its altitude in the air. The throttle must be pushed upwards beyond center point for the aircraft to completely takeoff from the ground. The harder the throttle is pushed, the faster the aircraft will ascend. Please push the throttle slowly for a gradual lift and to prevent the aircraft from ascending erratically.</p>	
<div style="display: flex; justify-content: space-around;"> <div style="text-align: center;">  <p>Mode 2 (American Hand)</p> </div> <div style="text-align: center;">  <p>Mode 1 (Japanese Hand)</p> </div> </div>	<div style="text-align: center;">  <p>Counterclockwise</p> <p>Clockwise</p> </div>
<p>The rudder is used to control the aircraft's rotations. Push the joystick to the left and the aircraft rotates counterclockwise. Push the joystick to the right and the aircraft rotates clockwise. When the joystick is centered (unmoving), the angular velocity of the aircraft is "0" and the aircraft will not turn. How hard the rudder is pushed will determine the angular velocity of the aircraft's rotation. The harder the rudder is pushed, the faster the aircraft rotates.</p>	
<div style="display: flex; justify-content: space-around;"> <div style="text-align: center;">  <p>Mode 2 (American Hand)</p> </div> <div style="text-align: center;">  <p>Mode 1 (Japanese Hand)</p> </div> </div>	<div style="text-align: center;">  <p>Forward</p> <p>Backward</p> </div>
<p>The elevator controls the aircraft's forward and backward movement. Push the joystick forward and the aircraft will tilt and fly forward. Pull the joystick back and the aircraft will tilt and fly backwards. When the joystick is centered (unmoving), the aircraft will hold its altitude in the air. How hard the elevator is pushed will determine the degree of the aircraft's tilt and therefore the velocity of its forward and backward movement. The harder the elevator is pushed, the greater the aircraft's tilt angle and flight speed either forwards or backwards.</p>	

REMOTE CONTROL		AIRCRAFT
		
Mode 2 (American Hand)	Mode 1 (Japanese Hand)	<p>NOTE: When the aircraft's head faces the pilot during flight, all control inputs from the joysticks will be backwards.</p>
<p>The aileron controls the aircraft's left and right movement. Push the joystick to the left and the aircraft will tilt and fly leftwards. Pull the joystick to the right and the aircraft will tilt and fly rightwards. When the joystick is centered (unmoving), the aircraft will hold its altitude in the air. How hard the aileron is pushed will determine the degree of the aircraft's tilt and therefore the velocity of its left and right movement. The harder the aileron is pushed, the greater the aircraft's tilt angle and flight speed either leftwards or rightwards.</p>		

6.4 Arming/Disarming the Motors

Arming/starting motors

Simultaneously pull the transmitter joysticks diagonally down-out to arm the motors (as shown in the side figure).

Disarming/stopping motors

Simultaneously pull the transmitter joysticks diagonally down-out to disarm the motors (as shown in the side figure).



Note: Pilots may also disarm the aircraft motors by holding the throttle in its lowest position after the aircraft has completed its descent on the ground.

 Please disarm the motors first before turning off the remote. If you turn off the remote first, the aircraft will attempt to perform a landing.

7 ADVANCED FLIGHT SETTINGS

7.1 Normal and Expert Mode

Whenever it is powered on, this aircraft will default to "Normal Mode". Although this aircraft responds quickly in "Normal Mode", it is even more fragile in "Expert Mode". When the aircraft has entered "Expert Mode", the remote screen will display "Expert".

Operation: Short press the non-throttle joystick to switch between "Normal Mode" and "Expert Mode". Entering Expert Mode will cause the transmitter to beep twice; exiting Expert Mode will result in one beep.

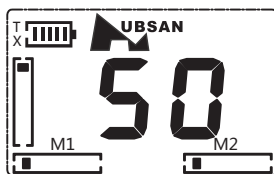

Normal Mode

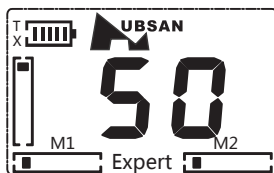

Expert Mode

7.2 Acro Mode

Press down on and hold the throttle stick to enter Acro Mode. The remote control will "beep" to indicate that the aircraft is ready to do flips and rolls.

7.2.1 Front flip

Short press on the throttle (you should feel and hear a click) and push the aileron stick forward. The aircraft will perform a front flip.



Mode 1
(American Hand)



Mode 2
(Japanese Hand)

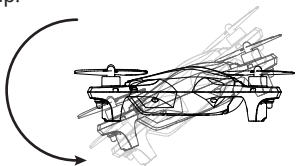

7.2.2 Back flip

Short press on the throttle (you should feel and hear a click) and push the aileron stick backward. The aircraft will perform a back flip.



Mode 1
(American Hand)



Mode 2
(Japanese Hand)

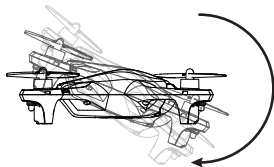

7.2.3 Left roll

Short press on the throttle (you should feel and hear a click) and push the aileron stick left. The aircraft will perform a left roll.



Mode 1
(American Hand)



Mode 2
(Japanese Hand)

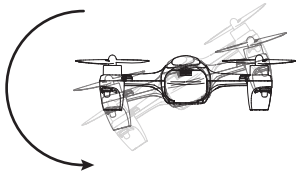

7.2.4 Right roll

Short press on the throttle (you should feel and hear a click) and push the aileron stick right. The aircraft will perform a right roll.



Mode 1
(American Hand)



Mode 2
(Japanese Hand)

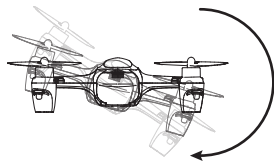

8 INSTALLING AND REMOVING PROPELLERS

Before installing propellers for the first time, please check that each Propeller A is matched with motor A and each Propeller B is matched with motor B. If propellers are improperly paired with the wrong motors, the aircraft will not be able to takeoff or fly properly and will most likely crash.

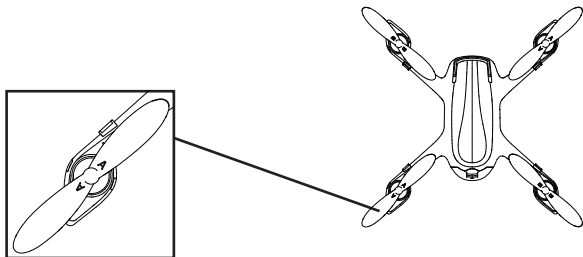

Removal: Hold the propeller and insert the U-shaped wrench right under the propeller hub. Press the wrench upward and the propeller will come off.

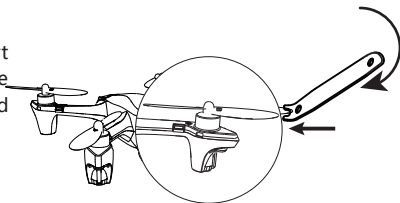

Installation: Hold the new propeller by its hub and press it firmly onto the motor shaft.

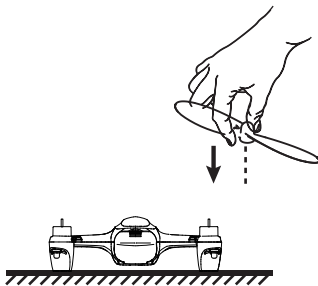

AIRCRAFT EXPLODED VIEW

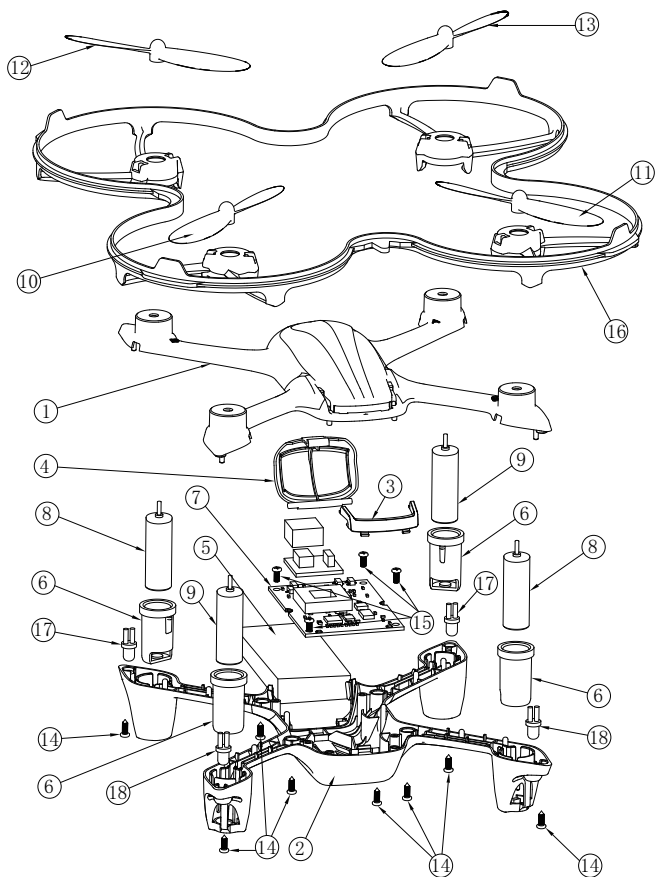

No.	Part Name	Qty	No.	Part Name	Qty
1	Body Shell (Top)	1	9	Motor A	2
2	Body Shell (Bottom)	1	10	Propeller A (Black)	1
3	Battery Compartment	1	11	Propeller B (Black)	1
4	Battery Compartment Cover	1	12	Propeller A (White)	1
5	Battery	1	13	Propeller B (White)	1
6	Motor Cover	4	14	Screw	8
7	PCB Motherboard	1	15	Screw	4
8	Motor B	2	16	Propeller Guard	1

H107P FREQUENTLY ASKED QUESTIONS

1. Aircraft and remote control are not pairing.

Restart the aircraft and its remote. Power on the aircraft first, followed by the transmitter.

2. The transmitter powers on, then shuts off immediately after.

The remote control battery voltage is too low. Check that the batteries is installed correctly. If needed, please replace with fresh AAA batteries.

3. The propellers aren't spinning, or are spinning very slowly.

(1) Aircraft battery voltage is too low.

(2) Aircraft and transmitter need a rebind.

(3) Pull the throttle to its lowest position and wait 3 seconds before attempting to fly again.

(4) Check whether the propellers are stuck too far down the motor shaft.

4. Aircraft is incapable of rolling or flipping.

(1) Use Expert Mode if not already active.

(2) The battery is too low on power.

5. Aircraft shakes and/or is very noisy during flight.

Answer: Check that motors, aircraft body and propellers are installed correctly.

Also see if the propellers are deformed or damaged.

6. Switching between Expert and Normal Mode is not consistent or smooth.

Make sure that when you are pressing on the non-throttle stick to enter and exit

Expert Mode, that the press is short and gentle, but firm.

7. The propellers are spinning, but the aircraft will not takeoff

(1) Check that all propellers are correctly installed. Please install propellers correctly as shown below if there are some matched with incorrect motors.

(2) Motor(s) are/is installed incorrectly. Check to make sure that each motor is installed correctly: each motor has two differently colored motor wires. Please check the figure on how to redo incorrectly installed motors.

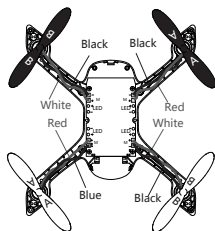
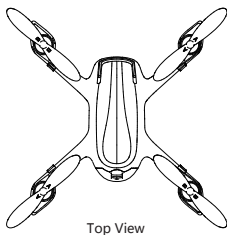

9. How to remove and install LEDs

Disassembly: Remove body screws; detach the body shell halves and all 4 feet. Desolder the selected LED's red and yellow wires from the PCB.

Installation: Solder the red wire of the selected to the positive pole (+), the yellow wire to the negative pole (-). Press the LED wires into their designated grooves in the aircraft arms; do the same for the motor wires. Screw the body shell back together and reinstall the aircraft feet. You can identify the color of each LED based on the color of the tube underneath the lamp shade: the blue LED's tubing is blue and the red LED's tubing is red.

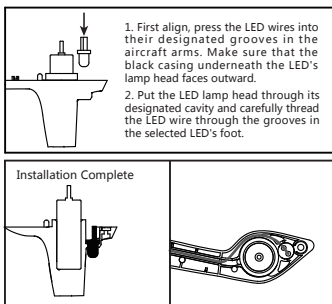
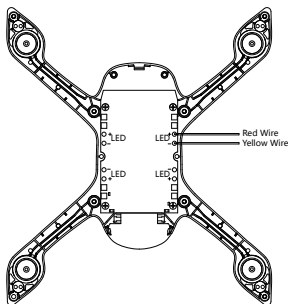

10. Motor(s) does not turn after a fall or crash.

Check for and remove any foreign material on the motor or motor shaft. If a propeller or propellers still does not turn, replace the motor. Check to see if a propeller is stuck on its motor shaft as well.

11. One or more motors does not function.

- (1) Rotate the affected motor propeller to check whether it's pressed too far down onto the motor.
- (2) Check to see if any motor wires are detached from the motherboard. If so, please re-solder the motor wire(s) back onto their designated points.
- (3) Replace the motor.

12. The aircraft consistently drifts in a specific direction.

(1) Place the aircraft on a completely horizontal and unmoving surface. Hold the yaw/rudder stick to the most down-right diagonal corner of its socket. Rapidly wiggle the aileron stick left and right continuously until all 4 LEDs flash simultaneously. Calibration is complete when all 4 LED indicators stop flashing. It is recommended that users wait for 15-20 seconds after the calibration is completed before flying again.

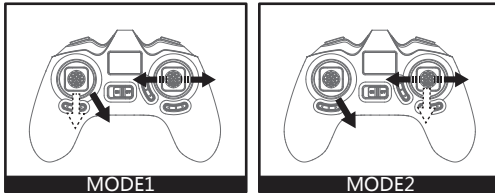

(2) If the aircraft still drifts a lot in a specific direction, add a few pieces of paper (the worse the drifting is, the more sheets you will need) under the foot of the aircraft (that points in the drift-affected direction).

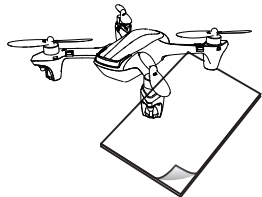

H107P PARTS & ACCESSORIES



H107P-04
BODY SHELL



H107-A02
PROPELLERS

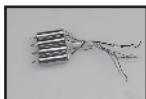

H107P-07
MOTORS



H107P-12
PCB MOTHERBOARD



H107P-09
BATTERY



H107-A06
USB CHARGER



H107P-16
SCREW SET



H107P-14
TRANSMITTER



H107-A11
WRENCH



H107-A13
T-SHIRT

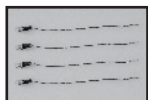

H107P-02
BLUE LED

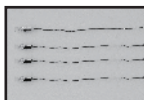

H107P-03
RED LED



H107P-01
SCREWDRIVER



H107P-06
CANOPY



H107P-10
MOTOR SLEEVE



H107P-05
BATTERY
COMPARTMENT
COVER



H107P-11
PROPELLER GUARD



H107P-15
CRASH KIT

This manual is subject to change without notice.

WWW.HUBSAN.COM

Version 2.0

