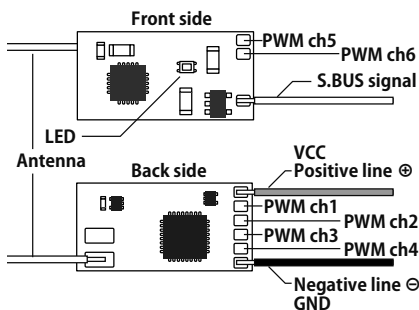

Futaba**S.BUS****T-FHSS**
AIR MONOHigh Voltage System
HV**T-FHSS Air (Mono Directional) -2.4GHz System**
S.BUS+6 Channels for parkflight /indoor plane
or small size aircrafts**Micro receiver material**
R3206SBM**This product requires fine soldering and**
installation of heat shrink tubing.**Limited flight range: 300ft. max.****Applicable systems: Futaba T-FHSS**
Air-2.4GHz system transmitter**R3206SBM is T-FHSS AIR system, but**
does not include telemetry functions.

When using S.BUS, solder the S.BUS line of S.BUS equipment to S.BUS wiring of R3206SBM. When using PWM, solder the signal line directly to ch1 to ch6 of the board. Also solder the power wiring to each device. (See the back side)

Compliance Information Statement (for U.S.A.)

This device, trade name Futaba Corporation, model number R3206SBM, complies with part15 of the FCC Rules. Operation is subject to the following two conditions:

- (1) This device may not cause harmful interference, and
 - (2) This device must accept any interference received, including interference that may cause undesired operation.
- The responsible party of this device compliance is: FUTABA Corporation of America
2681 Wall Triana Hwy Huntsville, AL 35824, U.S.A.
Phone:1-256-461-9399 FAX:1-256-461-1059
E-mail: service@futabaUSA.com

FEDERAL COMMUNICATIONS COMMISSION INTERFERENCE STATEMENT

This equipment has been tested and found to comply with the limits for a Class B digital device, pursuant to Part 15 of the FCC Rules. These limits are designed to provide reasonable protection against harmful interference in a residential installation. This equipment generates, uses and can radiate radio frequency energy and, if not installed and used in accordance with the instructions, may cause harmful interference to radio communications. However, there is no guarantee that interference will not occur in a particular installation. If this equipment does cause harmful interference to radio or television reception, which can be determined by turning the equipment off and on, the user is encouraged to try to correct the interference by one or more of the following measures:

- Reorient or relocate the receiving antenna.
- Increase the separation between the equipment and receiver.
- Connect the equipment into an outlet on a circuit different from that to which the receiver is connected.
- Consult the dealer or an experienced radio/TV technician for help.

Compliance Information Statement (for Canada)

CAN ICES-3(B)/NMB-3(B)

Compliance Information Statement (for EU)

Declaration of Conformity
Hereby, Futaba Corporation declares that the radio equipment type R3206SBM is in compliance with Directive 2014/53/EU. The full text of the EU declaration of conformity is available at the following internet address:

<http://www.rc.futaba.co.jp/english/dl/declarations.html>**FUTABA CORPORATION**oak kandakajicho 8F 3-4 Kandakajicho, Chiyoda-ku, Tokyo
101-0045, Japan

TEL: +81-3-4316-4820, FAX: +81-3-4316-4823

©FUTABA CORPORATION 2018, 7 (1)



Thank you for purchasing the R3206SBM T-FHSS S.BUS+6(six)channels receiver. This receiver is designed to be used with park fliers or small multi-copters.

Usage precaution

- Do not exceed 300ft.(100m) for flight range.
- Futaba T-FHSS Air system does not work with current Futaba S-FHSS / FHSS / FASST / FASSTest systems.
- The R3206SBM receiver can only be used with T-FHSS Air capable transmitters.
- This model is designed for short range application such as small size use aircrafts. Please read the usage condition shown below.

❗ Changes or modification not expressly approved by the party responsible for compliance could void the user's authority to operate the equipment.

❗ The R3206SBM receiver should be protected from vibration by foam rubber, hook and loop tape, or similar mounting methods. Protect from moisture.

❗ Keep away from conductive materials to avoid short circuits.

❗ Before flying, check operation of the R3206SBM and all the soldering part.

❗ It is cautious of the burn and fire in wiring work enough.

⊘ Do not near the transmitter and receiver within 10 inches.

- Doing so may cause erroneous operation.

⊘ Do not use it for a middle or large scale model.

⊘ Do not expose the receiver to high temperatures.

- The shrink cover could become distorted.

⊘ Do not break the tube.

- Could cause a short circuit.

Link to the transmitter

Each transmitter has an individually assigned, unique ID code. In order to start operation, the receiver must be linked with the ID code of the transmitter with which it is being paired. Once the link is made, the ID code is stored in the receiver and no further linking is necessary unless the receiver is to be used with another transmitter. When you purchase additional receivers, this procedure is necessary; otherwise the receiver will not work. Easy Link ID allows T-FHSS Air receivers to link to compatible transmitter without pressing the link button on the receiver.

- 1** Bring the transmitter and the receiver close to each other, by 20 to 40 inches.(0.5-1m) [However, it should not be within 10 inches.]
- 2** Turn on the transmitter. Place the transmitter into the receiver linking mode.
- 3** Turn on the receiver.
- 4** The receiver will wait for the linking process to begin for 3 seconds. Following that it will return to the normal operation mode.
- 5** When the LED of the receiver changes from blinking red to solid green, linking is completed. [NO LINK is displayed on the transmitter but there is no problem.]

* Refer to the transmitters operation manual for complete details on how to place the transmitter into the linking mode.

* If there are many T-FHSS Air systems turned on in close proximity, your receiver might have difficulty establishing a link to your transmitter. This is a rare occurrence. However, should another T-FHSS Air transmitter/receiver be linking at the same time, your receiver could link to the wrong transmitter. This is very dangerous if you do not notice this situation. In order to avoid the problem, we strongly recommend you to double check whether your receiver is really under control by your transmitter.

* The R3206SBM uses the T-FHSS Air (Mono directional) system so if used with another T-FHSS Air transmitter, then the ID of the R3206SBM receiver will not be shown on the transmitter's display. A "NO LINK" indication or the ID of a previously linked T-FHSS Air receiver will be shown. Nevertheless, if the LED on the R3206SBM displays a steady green light it is linked with a transmitter. (Telemetry can not be used on the R3206SBM.)

⚠ WARNING

- ⊘ Do not perform the linking procedure while the motor's main wire connected or the engine is operating as it may result in serious injury.
- ❗ When the linking is complete, please cycle the receiver power and ensure the receiver is properly linked to the transmitter.
- ❗ Please power up your system in this order. Transmitter first, followed by the receiver.
If the R3206SBM receiver was previously linked to another transmitter, make sure that transmitter is not operating while linking the receiver to the new transmitter.

LED Indication

Green	Red	Status
Off	Solid	No signal reception
Solid	Off	Receiving signals
Blink	Off	Receiving signals but ID is unmatched
Alternate blink		Unrecoverable error (Memory, etc.)

S.BUS**What is S.BUS?**

Different from conventional radio control systems, the S.BUS system uses data communication to transmit control signals from a receiver to a servo, gyro, or other S.BUS compatible devices. This data includes commands such as "move the channel 3 servo to 15 degrees, move the channel 5 servo to 30 degrees" to multiple devices. The S.BUS devices execute only those commands for their own set channel. For this reason, it can be used by connecting multiple servos to the same signal line.

⚠ WARNING

- ❗ Turn on the power on transmitter → receiver in order. In addition, always check the operation of all the functions before flight.
Please power up your system in this order. Transmitter first, followed by the receiver.

R3206SBM Specifications

T-FHSS Air (Mono Directional) -2.4GHz system/
S.BUS+6 channels receiver (No telemetry)

- Frequency band: 2.4GHz band
- Size: 1.24 x 0.39 x 0.12 in. (20.0 x 10.0 x 3.0 mm)
- Weight: ~ 0.04 oz. (1.0g)
- Power requirement: 3.2V to 8.4V
- Battery F/S Voltage: It sets up with a transmitter

Connection example

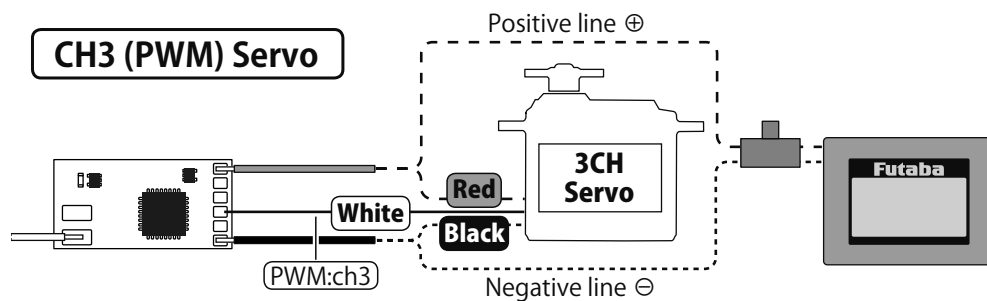
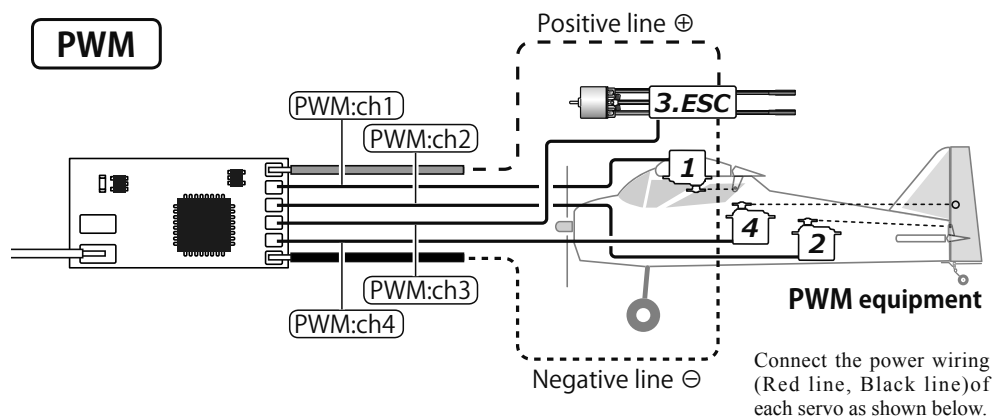
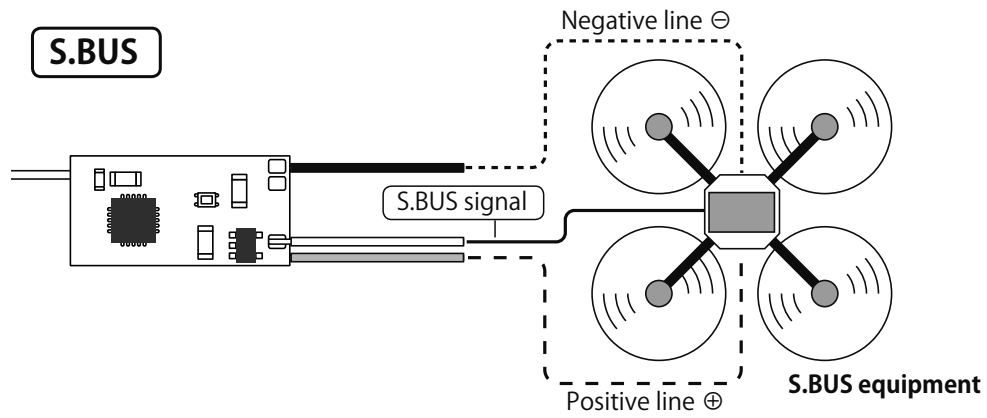

⚠ WARNING

❗ Solder the wiring securely. And cover the solder joint with an insulating tube.

Cover with heat shrink tube

After wiring is completed, cover the RX with heat shrink tubing.



Shrink with the heat gun.

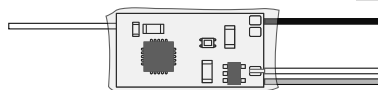
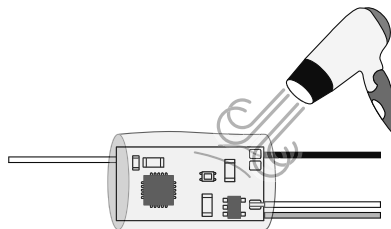

⚠ WARNING

❗ Be careful not to put too high of temperature directly aimed at the receiver.